

# Nice

## IBT4ZWAVE

CE

### BusT4 - Z-Wave interface

TR - Kurulum ve kullanım talimatları ve uyarıları



Nice

# 1

## GENEL GÜVENLİK TALİMATLARI

- **DİKKAT!**– Bu kılavuz, kişisel güvenliğinizi için önemli talimatlar içermektedir. Bu kılavuzun tüm bölümlerini dikkatlice okuyun. Şüphelenirseniz, kurulumu hemen durdurun ve Nice Müşteri Hizmetleri ile iletişime geçin.
- **DİKKAT!**– Önemli notlar: Bu kılavuzu daha sonraki bakım çalışmaları için güvenli bir yerde saklayın ve uygun şekilde bertaraf edilmesini sağlayın.
- **DİKKAT!**– Tüm montaj ve bağlantı işleri sadece uygun kalifiye ve eğitilmiş personel tarafından yapılmalıdır. Yetkili personel tarafından gerçekleştirilmeli, bağlanacak cihazın şebekeden ayrılması gerekmektedir.
- **Önemli!**– BUST T4 bağlantısı zaten IBT4N adaptörü tarafından kullanılıyorsa, BiDi-ZWave 'i artık kontrol paneline bağlayamazsınız.
- Bu ürün sadece iç mekanda kullanım içindir veya kontrolör muhafazası ile elemanlardan korunmalıdır.
- Ürün ambalajı yerel yönetmeliklere uygun olarak imha edilmelidir.
- Cihaz sadece bakım gerektirmeyen devreler içerdiğinden cihazın koruyucu kapağını açmayın.
- Cihazın hiçbir parçasını değiştirmeyin. İzin verilmeyen eylemler arızalara neden olabilir. Üretici hasar için tüm sorumluluğu reddeder.
- değiştirilmiş ürünün kullanımından kaynaklanan
- Cihazı ısı kaynaklarının yakınına koymayın ve açık alev maruz bırakmayın.
- Bu, cihaza zarar verebilir ve arızalara neden olabilir.
- Ürün, kısıtlı fiziksel, duyuşsal veya zihinsel yeteneklere veya uygun deneyime veya bilgiye sahip olmayan (çocuklar dahil) kişilere yöneliktir. Gözetiminde olmaları dışında Güvenliklerinden sorumlu olan ve onlar tarafından kullanım konularında eğitim almış kişiler.
- Çocukların cihazla oynamasına izin vermeyin.
- Cihazın çalıştığı sürücünün kullanım kılavuzundaki uyarıları da dikkate alın.
- Cihazı dikkatli tutunuz ve cihaza zarar vermemek için ezilme, çarpma ve düşmelerden kaçınınız.

# 2

## ÜRÜN AÇIKLAMASI

– **Dikkat! Burada veya aşağıda belirtilenler dışındaki koşullar altında herhangi bir kullanım Bu kılavuzda belirtilenler dışındaki çevresel koşullar kabul edilemez ve kesinlikle yasak**

BiDi-ZWave, hareketi izlemek için Z-Wave™ iletişimini kullanmanıza izin veren bir eklenti cihazdır ve BusT4 (Opera) protokolü ile uyumlu Nice Gate & Door otomasyonunun durumunu kontrol eder.

Ürünü kurmadan önce aşağıdakileri kontrol edin ve hazırlayın:

- Gate & Door serisinden BUS T4 soketi ile donatılmış 1 güzel merkezi ünite
- 1 Z-Wave denetleyicisi
- BiDi ZWave cihazının Z-Wave aralığını artırmak istiyorsanız, şunları da hazırlayın:
- teknik şartnameye uygundur (dahil değildir)

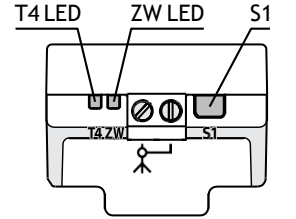

# 3

## KURULUM

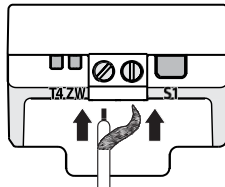

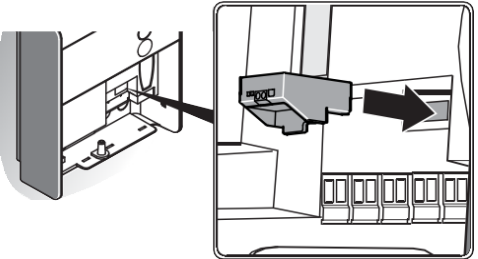
01.	Merkezi üniteye giden güç beslemesini kesin	OFF 
02.	Devam etmeden önce merkezi üniteye tüm LED'ler kapalı olmalıdır.	
03.	Harici bir anten bağlamak isterseniz, Şimdi yapınız. ⚠ Dikkat! Yalnızca antenleri ve kabloları kullanın teknik şartnameye uygun ekipman (bkz. bölüm 10)!	
04.	If present, remove the plastic pre-cut element from BUS T4 connector and check that there are no burrs	
04.	Insert the IBT4ZWAVE into the BUS T4 port of the connector unit ⚠ Caution! If the IBT4ZWAVE is inserted incorrectly, it may permanently damage the control unit!	

05.	Power the automation's control unit	
06.	LEDs on the IBT4ZWAVE will show adding and antenna status (Table 1)	
07.	Wait for the IBT4ZWAVE to finish initialization sequence (T4 LED flashing green)	
08.	Add the device to the Z-Wave network; for the relevant procedure see Chapter 4	

## 4

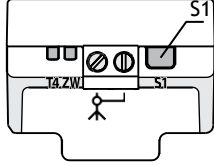
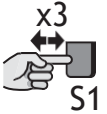

**⚠ Install the external antenna before powering the device and adding to the Z-Wave network for the device to automatically detect and enable it (use only antennas and cables compliant with technical specification – see chapter 10).**

### 4.1 - Adding manually

01.	Set the Z-Wave gateway into adding mode (see the Z-Wave gateway's manual)	
02.	On the IBT4ZWAVE press and release the S1 button 3 times	 
03.	LEDs on the IBT4ZWAVE will start slow flashing alternately	
04.	If you are adding in Security S2 Authenticated, input the underlined part of the DSK (label on the box)	DSK: <u>XXXXX</u> -XXXXX-XXXXX-XXXXX <u>XXXXX</u> -XXXXX-XXXXX-XXXXX
05.	When the adding process ends, the LEDs on the IBT4ZWAVE will show adding and antenna status (Table 1)	

### 4.2 - Adding using SmartStart

SmartStart enabled products can be added into a Z-Wave network by scanning the Z-Wave QR Code present on the product with a controller providing SmartStart inclusion. SmartStart product will be added automatically within 10 minutes of being switched on in the network range.

01.	To use SmartStart your Z-Wave gateway needs to support Security S2 (see the Z-Wave gateway's manual)	
02.	Disconnect the power supply from the automation's control unit	
03.	Enter the full DSK string code to your Z-Wave gateway. If your controller is capable of QR scanning, scan the QR code placed on the label on the device and bottom of the box	
04.	Power the automation's control unit	
05.	LEDs on the IBT4ZWAVE will start slow flashing alternately	
06.	When the adding process ends, the LEDs on the IBT4ZWAVE will show adding and antenna status (Table 1)	

## 5

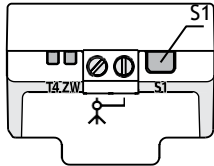
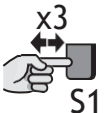
01.	Set the Z-Wave gateway into remove mode (see the Z-Wave gateway's manual)	
02.	On the IBT4ZWAVE press and release the S1 button 3 times	 
03.	LEDs on the IBT4ZWAVE will start slow flashing alternately	
04.	Wait for the removing process to end	





## 6

The IBT4ZWAVE is equipped with an internal antenna, but an external antenna can be connected to improve the Z-Wave network range, e.g. when the gate is far away from the house.

**⚠ Check the technical specification to buy the correct antenna and cable (see chapter 10)!**

## 6.1 - Checking and switching enabled antenna

External antenna will be detected and enabled automatically after powering the device (if not added to the Z-Wave network), but you can switch manually between antennas using the following procedure.

01.	Press and hold the S1 button	
03.	Wait 3 seconds	
04.	LEDs will show adding and antenna status (Table 1) for 3 seconds	
05.	LEDs will turn off for 3 seconds	
06.	When LEDs show the selected antenna, release the button: ZWLED (blue) for internal antenna, T4 LED (green) for external antenna (Table 2)	
07.	If you want to switch the antenna, press and release the S1 button	
08.	If the antenna was switched, the corresponding LED will flash 2 times: ZWLED (blue) for internal antenna, T4 LED (green) for external antenna (Table 2)	





## 7

To control the movement use Z-Wave gateway's interface or click the S1 button (works in Step-by-Step mode).

## 8

Reset procedure allows to restore the device back to its factory settings, which means all information about the Z-Wave gateway and user configuration will be deleted.

Resetting the device is not the recommended way of removing the device from the Z-Wave network. Use reset procedure only if the primary controller is missing or inoperable. Certain device removal can be achieved by the procedure of removing described.

01.	Press and hold the S1 button	
03.	Wait 3 seconds	
04.	LEDs will show adding and antenna status (Table 1) for 3 seconds	
05.	LEDs will turn off for 3 seconds	
06.	LEDs will show selected antenna (Table 2) for 3 seconds	
07.	When both LEDs light up simultaneously, release the button	
08.	Press and release the S1 button	
09.	Both LEDs will flash once at the end of the procedure	 T4 ZW

## 9

**Table 1 - LEDs Z-Wave and antenna status**

T4 LED (green)	ZW LED (blue)	Z-Wave adding status	External antenna
OFF	ON for 3 seconds	Not added	Not connected
OFF	2 flashes	Added (non-secure, S0, S2 Unauthenticated)	Not connected
OFF	4 flashes	Added successful (Security S2 Authenticated)	Not connected
ON	ON for 3 seconds	Not added	Connected
ON	2 flashes	Added (non-secure, S0, S2 Unauthenticated)	Connected
ON	4 flashes	Added successful (Security S2 Authenticated)	Connected

**Table 2 - LEDs selected antenna**

T4 LED (green)	ZW LED (blue)	Selected antenna
OFF for 3 seconds	ON for 3 seconds	Internal
ON for 3 seconds	OFF for 3 seconds	External

The product IBT4ZWAVE is produced by Nice S.p.a. (TV). Warnings: - All technical specifications stated in this section refer to an ambient temperature of 20°C (± 5°C) - Nice S.p.a. reserves the right to apply modifications to the product at any time when deemed necessary, while maintaining the same functionalities and intended use.

IBT4ZWAVE	
Type	control using Z-Wave network of devices fitted with connector compatible with BUS T4
Technology adopted	half duplex 19200 Bps serial connection on differential bus
Power supply	24V DC supplied by the control unit to which the IBT4ZWAVE is connected
Absorbed current	max 50 mA
Radio frequencies	868.0–868.6; 869.7–870.0 MHz
Internal antenna max. transmit power	10 dBm
External antenna center frequency	868 MHz
External antenna max. peak gain	3 dBi
External antenna max. transmit power	13 dBm
External antenna cable length	1 – 3 m
Antenna connector screws rated torque	0.4 Nm
Casing protection rating	IP 40 (use indoors or in protected environments only)
Operating temperature	- 20 °C ÷ +50 °C
Dimensions (mm)	37 x 28 x h 21
Weight	10g

**The device is a Security Enabled Z-Wave Plus™ product and a Security Enabled Z-Wave gateway must be used in order to fully utilize the product.**

The device may be used with all devices certified with the Z-Wave Plus certificate and should be compatible with such devices produced by other manufacturers.

The device works as a Z-Wave signal repeater (all non-battery operated devices within the network will act as repeaters to increase reliability of the network).

**Generic Device Type:** GENERIC\_TYPE\_SWITCH\_MULTILEVEL (0x11)

**Specific Device Type:** Not Used

**Table 3 - Supported Command Classes**

Command Class	Version	Secure
COMMAND_CLASS_ZWAVEPLUS_INFO [0x5E]	V2	
COMMAND_CLASS_MULTILEVEL_SWITCH [0x26]	V4	YES
COMMAND_CLASS_ASSOCIATION [0x85]	V2	YES
COMMAND_CLASS_MULTI_CHANNEL_ASSOCIATION [0x8E]	V3	YES
COMMAND_CLASS_ASSOCIATION_GRP_INFO [0x59]	V3	YES
COMMAND_CLASS_DEVICE_RESET_LOCALLY [0x5A]	V1	YES
COMMAND_CLASS_FIRMWARE_UPDATE_MD [0x7A]	V5	YES
COMMAND_CLASS_INDICATOR [0x87]	V3	YES
COMMAND_CLASS_MANUFACTURER_SPECIFIC [0x72]	V2	YES
COMMAND_CLASS_POWERLEVEL [0x73]	V1	YES
COMMAND_CLASS_SECURITY [0x98]	V1	
COMMAND_CLASS_SECURITY_2 [0x9F]	V1	
COMMAND_CLASS_SUPERVISION [0x6C]	V1	
COMMAND_CLASS_TRANSPORT_SERVICE [0x55]	V2	
COMMAND_CLASS_VERSION [0x86]	V3	YES
COMMAND_CLASS_NOTIFICATION [0x71]	V8	YES
COMMAND_CLASS_APPLICATION_STATUS [0x22]	V1	
COMMAND_CLASS_PROTECTION [0x75]	V2	YES
COMMAND_CLASS_CONFIGURATION [0x70]	V4	YES
COMMAND_CLASS_BASIC [0x20]	V2	YES

**Table 4 - Association Command Class**

Group	Group Name	Profile	Max. Nodes Supported	Description
1	Lifeline	General: Lifeline (0x00: 0x01)	1	Reports the device status to the Z-Wave gateway

**Table 5 - Multilevel Switch Command Class / Basic Command Class mapping**

Basic Command	Mapped Command
Basic Set (Value)	Multilevel Switch Set (Value)
Basic Report (Current Value, Duration)	Multilevel Switch Report (Value, Duration)

**Table 6 - Multilevel Switch Command Class SET**

Value	Duration	Level	Description
0x00	Ignore	0%	Close
0x01-0x63	Ignore	100%	Open
0x64-0xFE	Ignore	reserved	
0xFF	Ignore	100%	Open

**Table 7 - Multilevel Switch Command Class Report**

State	Current Value	Target Value	Duration
Open	0x63	0x63	0x00
Opening	0xFE	0x63	0xFE
Stopped	0xFE	0xFE	0x00
Closing	0xFE	0x00	0xFE
Close	0x00	0x00	0x00

**Table 8 - Notification Command Class**

Notification Type	Event	Event/State Parameter	Status
Access Control (0x06)	Event: Barrier operation (open/close) force has been exceeded (Notification CC V4) (0x41) *	-	0xFF – enable (not changeable)
Access Control (0x06)	State: Barrier safety beam obstacle (Notification CC V4) (0x48) *	-	0xFF – enable (not changeable)
Access Control (0x06)	State: Barrier associated with non Z-Wave remote control (Notification CC V4) (0x4C)	-	0xFF – enable (not changeable)
System (0x09)	State: System hardware failure (Notification CC V2) [0x03]	0x05 - External device not detected	0xFF – enable (not changeable)

\* Some control units might not support this feature.

**Table 9 - Protection Command Class**

Type	State	Description	Action
Local	0	Unprotected - The device is not protected, and may be operated normally via the user interface.	S1 button controls gate state
Local	2	No operation possible – S1 button cannot change outputs state, any other functionality and control via gate controller unit's buttons is available.	S1 button doesn't control gate state
RF	0	Unprotected - The device accept and respond to all RF Commands.	Z-Wave requests can change gate state
RF	1	No RF control – command class basic and switch binary are rejected, every other command class will be handled	Z-Wave requests can't change gate state

**Table 10 - Indicator Command Class**

Indicator ID	Properties ID	Values and requirements
Node Identify (0x50)	Toggling On/Off Periods (0x03)	This property is used to set the duration in tenth of seconds of an On/Off period. 0x00..0xFF represent 0..25,5 seconds
Node Identify (0x50)	Toggling On/Off Cycles 0x04	This property is used to set the number of On/Off periods to run - 0x00..0xFE represent 0..254 times - 0xFF MUST indicate to run On/Off periods until stopped
Node Identify (0x50)	Toggling On time within an On/Off period (0x05)	This property is used to set the length of the On time during an On/Off period. It allows asymmetric On/Off periods. - The value 0x00 MUST represent symmetric On/Off period (On time equal to Off time) - Values in the range 0x01..0xFF MUST represent 0,1..25,5 seconds e.g. 300ms ON and 500ms OFF is achieved by using : On/Off period (0x03) = 0x08 and On time within an On/Off Period (0x05) = 0x03

**Table 11 - Configuration Command Class**

<b>30. Alarm configuration - 1st slot</b>	
Description	This parameter determines to which alarm frames and how the device should react. The parameters consist of 4 bytes, three most significant bytes are set according to the official Z-Wave protocol specification.
Parameter size	4B
Default value	[0x00, 0x00, 0x00, 0x00] (disabled)
Available values	1B [MSB] – Notification Type 2B – Notification Status 3B – Event/State Parameters 4B [LSB] – action: 0x00 – no action, 0x01 – open, 0x02 – close
<b>31. Alarm configuration - 2nd slot</b>	
Description	This parameter determines to which alarm frames and how the device should react. The parameters consist of 4 bytes, three most significant bytes are set according to the official Z-Wave protocol specification.
Parameter size	4B
Default value	[0x05, 0xFF, 0x00, 0x00] (Water Alarm, any notification, no action)
Available values	1B [MSB] – Notification Type 2B – Notification Status 3B – Event/State Parameters 4B [LSB] – action: 0x00 – no action, 0x01 – open, 0x02 – close
<b>32. Alarm configuration - 3rd slot</b>	
Description	This parameter determines to which alarm frames and how the device should react. The parameters consist of 4 bytes, three most significant bytes are set according to the official Z-Wave protocol specification.
Parameter size	4B
Default value	[0x01, 0xFF, 0x00, 0x00] (Smoke Alarm, any notification, no action)
Available values	1B [MSB] – Notification Type 2B – Notification Status 3B – Event/State Parameters 4B [LSB] – action: 0x00 – no action, 0x01 – open, 0x02 – close
<b>33. Alarm configuration - 4th slot</b>	
Description	This parameter determines to which alarm frames and how the device should react. The parameters consist of 4 bytes, three most significant bytes are set according to the official Z-Wave protocol specification.
Parameter size	4B
Default value	[0x02, 0xFF, 0x00, 0x00] (CO Alarm, any notification, no action)
Available values	1B [MSB] – Notification Type 2B – Notification Status 3B – Event/State Parameters 4B [LSB] – action: 0x00 – no action, 0x01 – open, 0x02 – close
<b>34. Alarm configuration - 5th slot</b>	
Description	This parameter determines to which alarm frames and how the device should react. The parameters consist of 4 bytes, three most significant bytes are set according to the official Z-Wave protocol specification.
Parameter size	4B
Default value	[0x04, 0xFF, 0x00, 0x00] (Heat Alarm, any notification, no action)
Available values	1B [MSB] – Notification Type 2B – Notification Status 3B – Event/State Parameters 4B [LSB] – action: 0x00 – no action, 0x01 – open, 0x02 – close

The device does not support Configuration CC Bulk commands.

## 12

This product is an integral part of the automation and therefore must be disposed together with the latter.

As in installation, also at the end of product lifetime, the disassembly and scrapping operations must be performed by qualified personnel. This product is made of various types of material, some of which can be recycled while others must be scrapped. Seek information on the recycling and disposal systems envisaged by the local regulations in your area for this product category.

**Caution!** – some parts of the product may contain pollutant or hazardous substances which, if disposed of into the environment, may cause serious damage to the environment or physical health.

As indicated by the symbol alongside, disposal of this product in domestic waste is strictly prohibited. Separate the waste into categories for disposal, according to the methods envisaged by current legislation in your area, or return the product to the retailer when purchasing a new version.

**Caution!** – local legislation may envisage serious fines in the event of abusive disposal of this product.





**PLACE FOR CE  
DECLARATION**

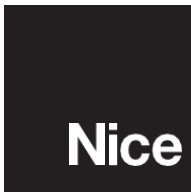

Nice SpA  
Oderzo TV Italia  
info@niceforyou.com

[www.niceforyou.com](http://www.niceforyou.com)